

FreeGlide®

The only In-Line Powder Sampler guaranteed not to jam



Patented

FreeGlide®

The smarter way to sample



Manually Operated
(model shown is FG-1500M)



TESTED
TO HALF A MILLION CYCLES

Pneumatic Actuation
(model shown is FG-3000A)

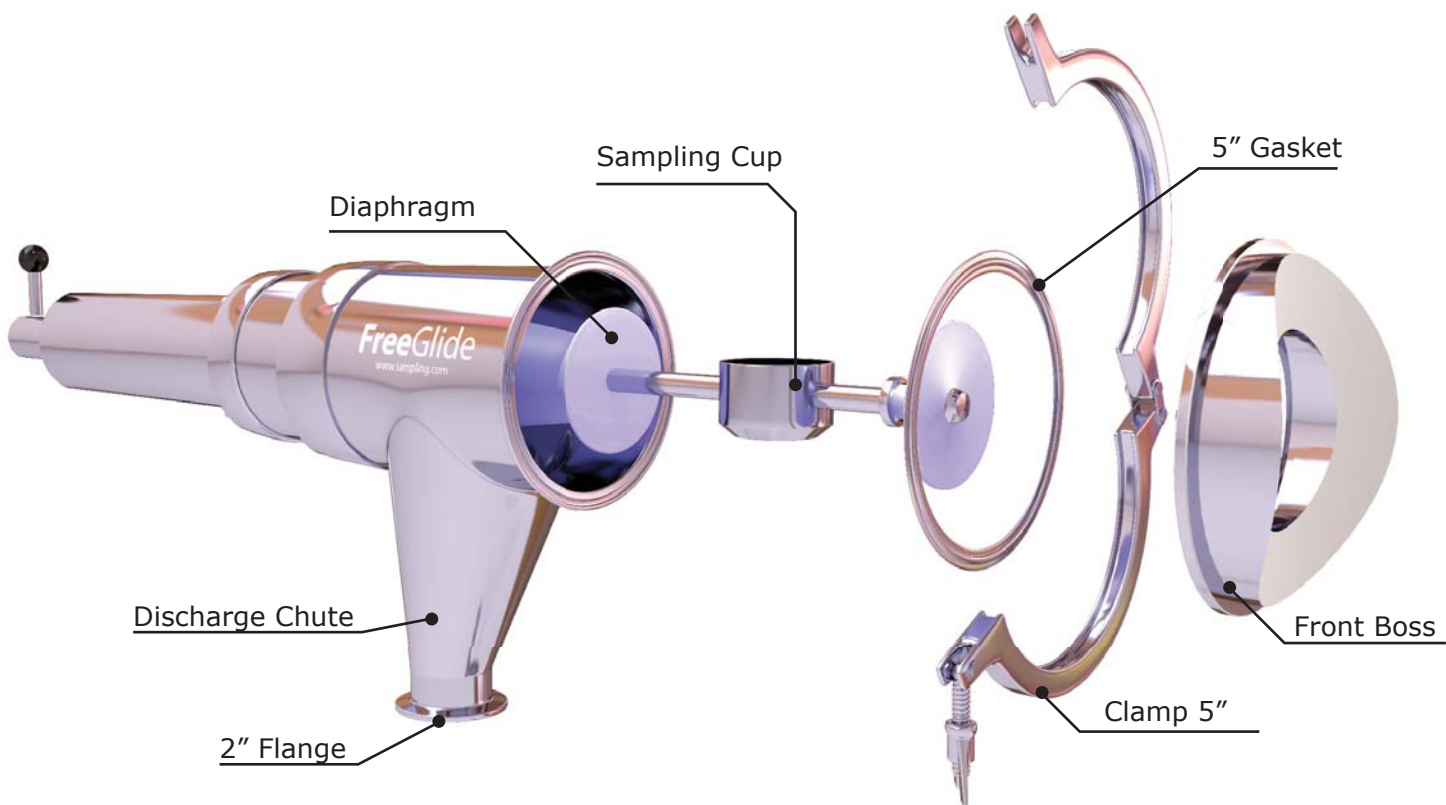

The FreeGlide® is the worlds leading inline powder sampler. It has been designed to take samples efficiently and quickly as the powder falls under gravity down a pipe or chute. The FreeGlide® is used in hundreds of pharmaceutical and food factories around the world.

Operation

Resting

When the FreeGlide® is not in use the full bore of the downpipe is available for powder flow.

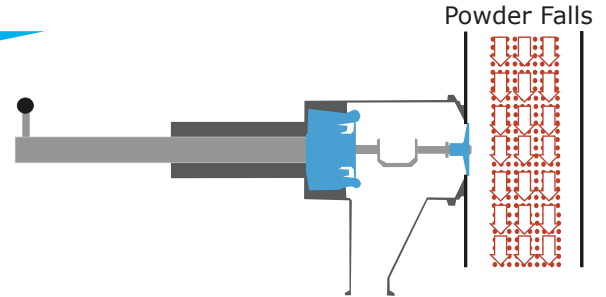

Sampling

The sampling cup is extended into the downpipe to catch the product as it falls.

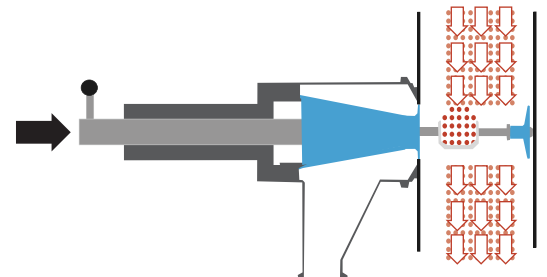

Discharging

The sampling cup is then retracted and inverted. The powder sample falls down the discharge chute to where it is collected.

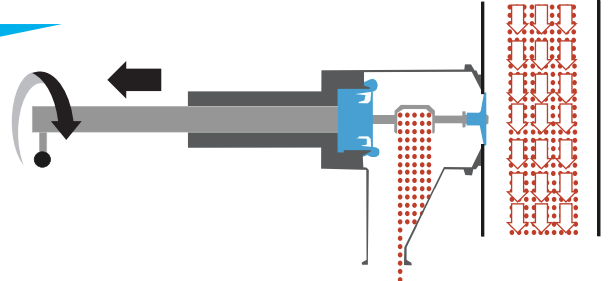

Guaranteed not to jam

The Flexible Diaphragm

At the heart of the FreeGlide® is an ingenious, patented, flexible diaphragm. The purpose of the diaphragm is to keep powder away from the working mechanisms of the sampler. By keeping the mechanisms clean the sampler will not jam in operation.

All product contact polymers used within the FreeGlide® are FDA acceptable.



FreeGlide® Advantages

Sampling Systems have spent many years developing and testing the FreeGlide®. This highly innovative device overcomes the problems inherent in other in-line powder samplers:

- It does not jam during use
- The sample is collected in a cup which does not alter the physical characteristics of the powder
- The full bore of the pipe is available for powder flow when the sampler is not in use
- Available for manual or automated sampling



Hygienic Applications

The FreeGlide® has been made to the latest Pharmaceutical GMP standards and so is ideal for hygienic applications. The product contact parts of the standard model are: 316 stainless steel, PTFE and silicone rubber (other materials are available on request).

Robust Construction

The FreeGlide® is exceptionally robust and is suitable for use in a wide range of industries including: pharmaceutical, food, chemical, general industrial and cosmetic.

Which FreeGlide?

How to determine the right FreeGlide®

The FreeGlide® is available in four sizes. The size required will depend upon the diameter of the pipe where the FreeGlide is to be installed.

Dimension A = distance to the centre line of the cup

Dimension B = distance to the end of the seal peg (this will be the minimum diameter of the pipe that the FreeGlide can be installed in)

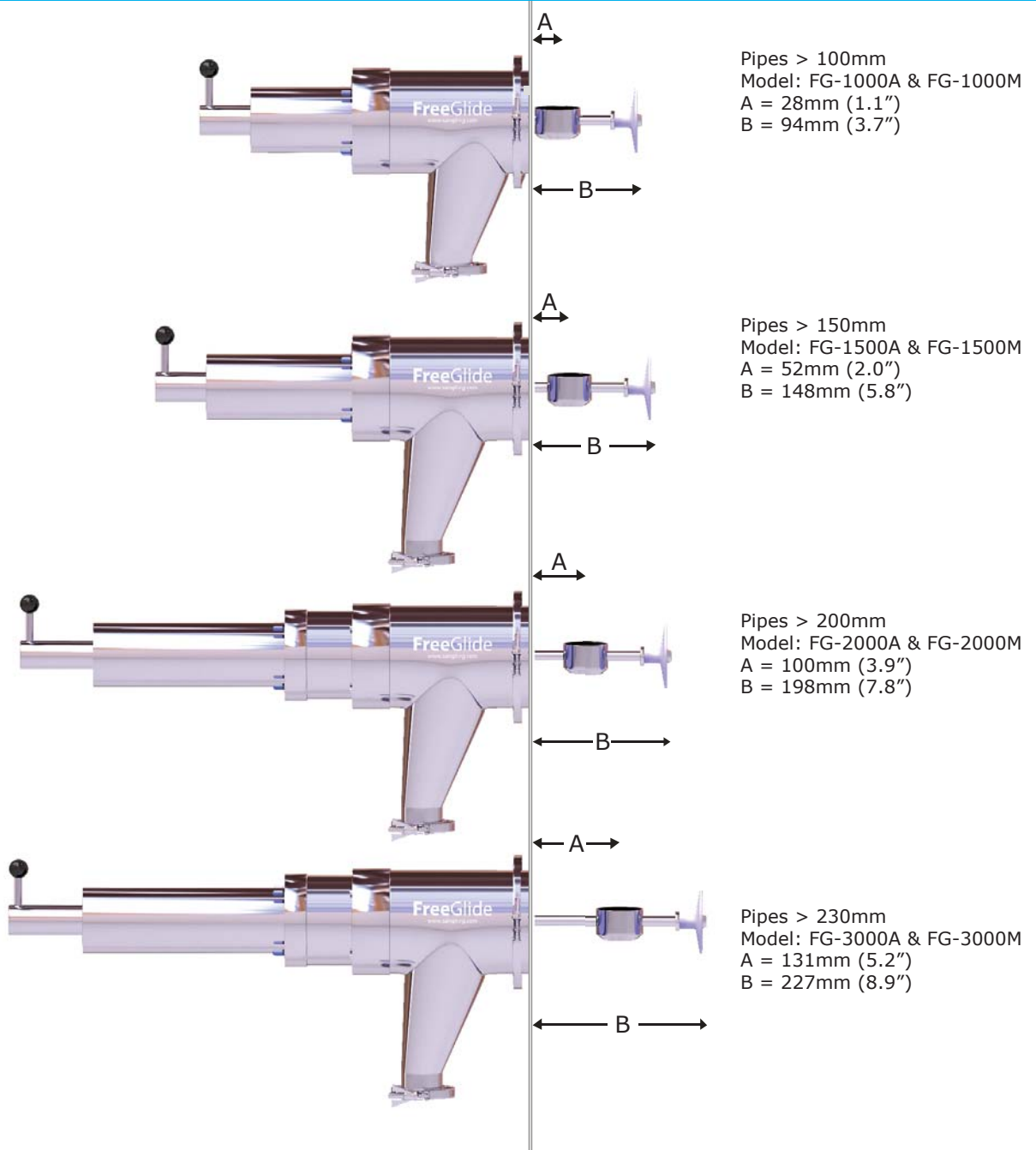

Minimum Downpipe Diameter	FreeGlide® Part Number	
	Manual	Actuated
100mm	FG - 1000M	FG - 1000A
150mm	FG - 1500M	FG - 1500A
200mm	FG - 2000M	FG - 2000A
230mm	FG - 3000M	FG - 3000A

Installation

1. Cut a hole in your downpipe
2. Weld the Front Boss to your downpipe.
3. The main body of the FreeGlide® then clamps to the front flange

Note: The FreeGlide® can be easily removed for cleaning

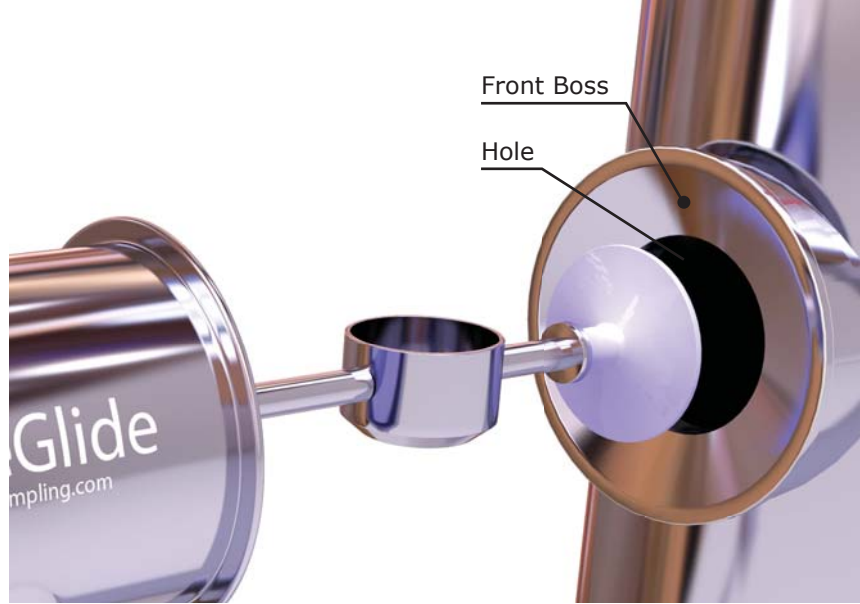

Sample Collection

When the Sampling Cup is inverted the product falls down the Discharge Chute.

The powder samples can be collected in a number of ways:

- Into a bottle attached using a PTFE Bottle Adapter
- Into a bag
- Collected using a cassette of continuous tubing which can be sealed and cut between sample collections

PTFE Bottle Adapter -

A PTFE Bottle Adapter can be custom made to suit virtually any bottle thread. The Bottle Adapter clamps to the Discharge Chute and the sample collecting bottle screws into Bottle Adapter

High Containment Sampling

Sampling Systems can offer high containment sampling through a 50mm high containment Split Butterfly Valve.

Containment levels of $< 10 \mu\text{g}/\text{m}^3$ (lower levels can be achieved depending on the product) Available in both 316L stainless steel and hastelloy with a range of seals including EPDM and Kalrez® Suitable for use with either stainless steel or plastic containers.

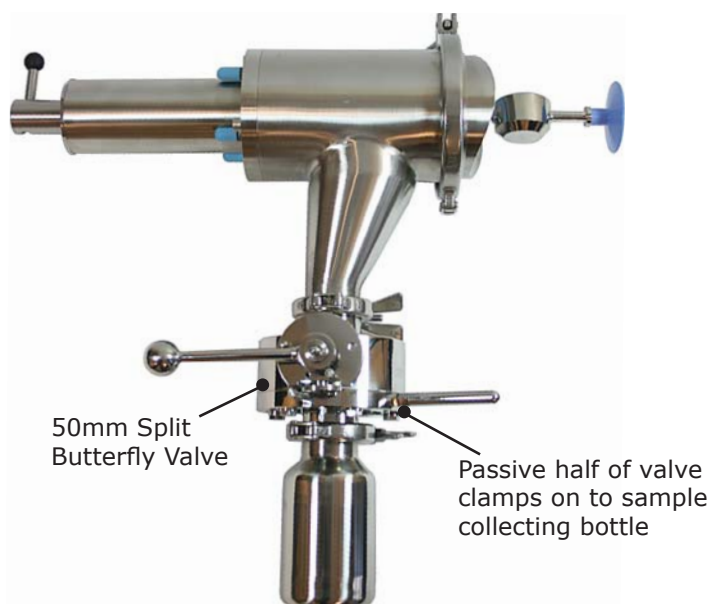

Technical

Contact parts:	<ul style="list-style-type: none">- 316L stainless steel- PTFE- Silicone rubber, Viton or EPDM
Non contact parts:	<ul style="list-style-type: none">- 304 grade stainless steel- Other materials as required.
Sample Volume:	50ml (nominal)
Finishes:	All welds ground and polished. All product contact surfaces are finished to Ra 0.5µm or finer
Actuation:	Manual or Pneumatic actuated Actuated FreeGlides® are supplied with reed and limit switches so they can be connected directly to your PLC. Please contact us for more information.
Dimensions:	Please contact us for planning in drawings

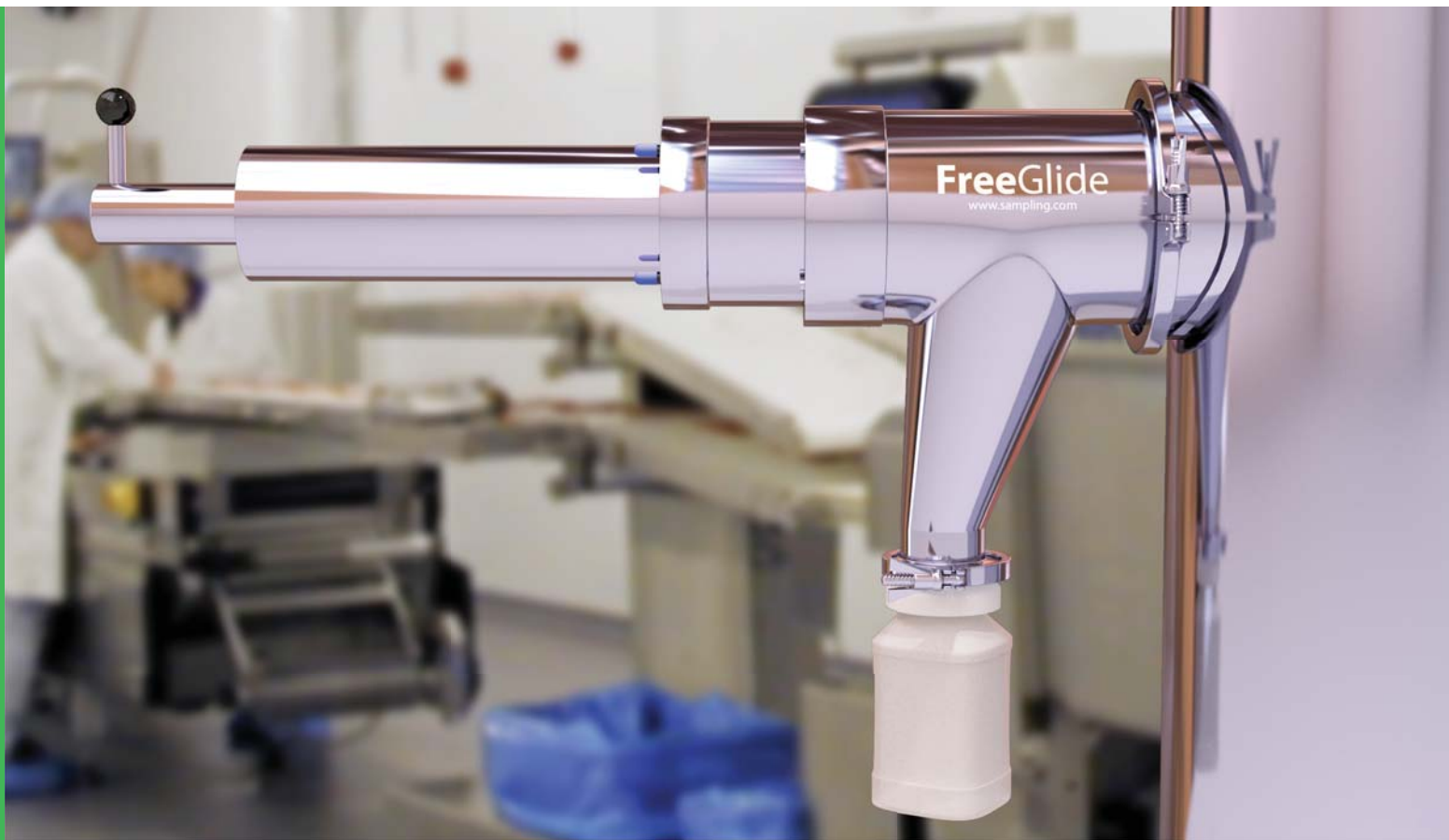

Suitability:

The FreeGlide® is designed for the collection of powder samples from a vertical downpipe. The product needs to be dispersed in air and in free fall.

Pipe Pressure:	The internal pressure differential across the device (inside/outside of the downpipe) needs to be within 0.1 barg of surrounding atmospheric pressure.
Flexible Parts:	Silicone, Viton or EPDM (FDA acceptable materials)
Temperature:	Product Temperature 10 to 60°C (50 to 140°F)



Further Information

If you are planning a new facility or looking to replace an old sampler please contact Sampling Systems. We will be able to supply full planning in drawings and quotes by return. With installations in a wide range of industries around the world we are sure we can help.

Worldwide Enquires

Sampling Systems have trained and experienced agents around the world who will be pleased to help with your enquiry. Please contact us for details of your local dealer.



Address:
Sampling Systems Ltd.
4 & 5 Forge Mills Park,
Coleshill.
B46 1JH.
UK

BY TELEPHONE
01675 466992 (from UK)
1-888-414-6448 (Toll Free from USA)
+44 (0)1675 466992 (International)

Email: info@sampling.com

Web: www.sampling.com

