

SDx™ SERIES

MID-SIZED SMART DRIVE EXCHANGEABLE PLATFORM

Advanced powder milling and
screening solutions on a
common drive



SDx™ SERIES

MID-SIZED SMART DRIVE EXCHANGEABLE PLATFORM

Unparalleled milling flexibility and improved powder processing efficiency.

The Fitzpatrick Company and Quadro Engineering Corp. are pleased to introduce one of the world's most advanced mid-sized / pilot-scale milling & screening platforms offering two distinct powder processing solutions on a single, common drive.

The mid-size SDx™ Series platform with exchangeable heads affords the ability to quickly and easily interchange Quadro's Comil® and FlexSift Security Screening technologies.

The SDx™ will help you to:

- **Increase production efficiency**
interchangeable heads reduce bottlenecks & increase capacity
- **Optimize particle size distributions (PSDs)**
improve on-target PSDs by 30 - 50% over similar technologies
- **Reduce capital investment & cost of ownership up to 75%**
ability to invest in two processes with a single, common drive
- **Program / control recipes**
enhanced HMI touchscreen controls with upgraded 3 HP (2.2 kW) ATEX 2GD marked motor
- **Enhance operator & product safety**
first conical mill & security screener with greaseless gearbox safeguards batches
- **Protect heat-sensitive products during milling**
patent-pending Comil screen designs lower temps as much as 30%



TECHNICAL DATA

Quadro® U10x Comil®

- Improve Particle Size Distributions (PSDs)
20 - 40% more on-target, an average 50% capacity increase & reduced milling temperatures
- Greaseless Gearbox Technology
50% lower gearbox temperatures & 5 - 10dB noise reduction



Quadro® S10x FlexSift

- Optimize security screening
one unit can replace multiple traditional vibratory sifters
- Best-in-class performance
40 - 50% more capacity vs. similar technologies



		U10x	S10x
Typical Pharma Capacities ¹	kg/hr	500 - 1000 ¹	1000 - 7500 ¹
Power	kW (HP)	2.2 (3)	2.2 (3)
Noise	dB	<75	<75
Height to Discharge (H)	mm (inches)	1000 (39)	1319 (52)
Height to Inlet (H2)	mm (inches)	1267 (50)	1267 (50)

¹ Capacity is dependent on product characteristics, final PSD target and equipment set-up. Please contact us for more information.

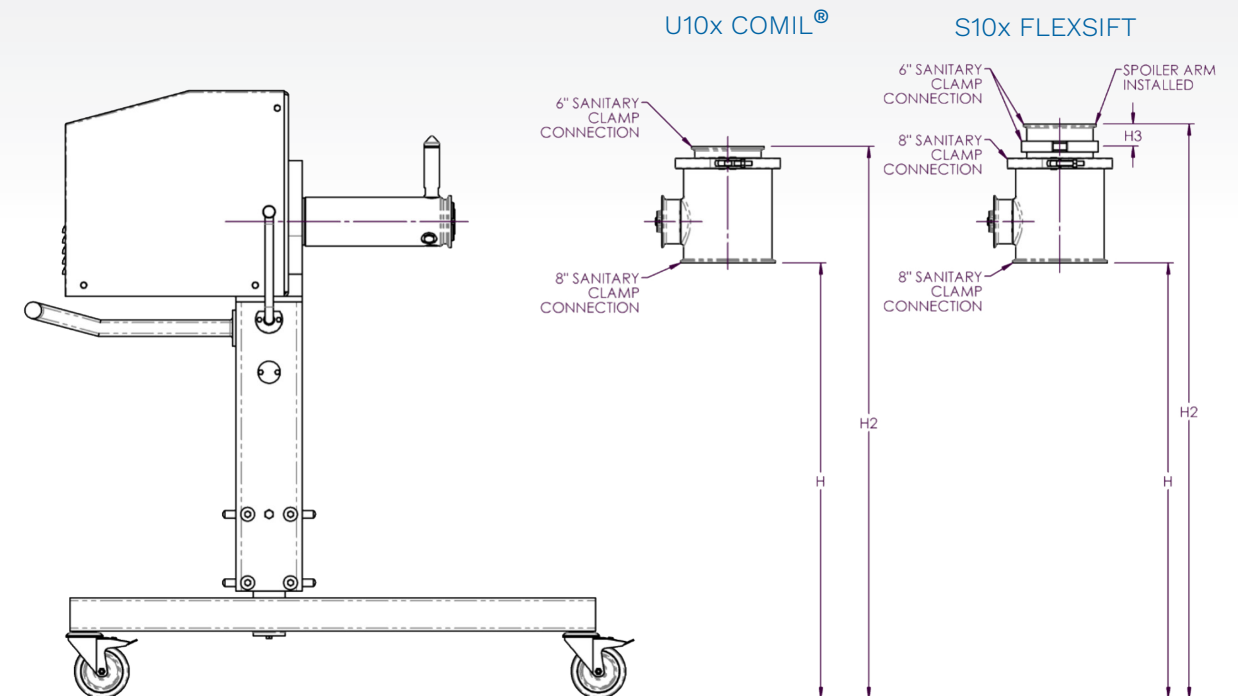

INNOVATIVE PRODUCTS BACKED BY WORLD-LEADING EXPERTISE AND SUPPORT



The Fitzpatrick Company and Quadro Engineering Corp. have earned the respect of customers for a combined period of over 120 years.

With over 40,000 equipment installations worldwide, discover what underscores our reputation for supplying high quality powder processing equipment solutions. Trust us to fulfill your specific application requirements.

Discover and experience the Fitzpatrick / Quadro difference!

● Headquarters

● IDEX MPT Centers of Excellence

Representation in over 80 countries worldwide

The Fitzpatrick Company
Tel: +1.519.884.9660
Email: fitzinfo@idexcorp.com
www.fitzpatrick-mpt.com

Quadro Engineering Corp.
Tel: +1.519.884.9660
Email: quadrosales@idexcorp.com
www.quadro-mpt.com

SDx Mid-Size 3/21



Fitzpatrick | Matcon | Microfluidics | Quadro | Steridose